

CHAPTER 7

Three-watt Amplifier

The circuit described in this chapter has been developed to meet the demand for a simple amplifier of reasonably high quality. The amplifier, which is operated from a.c. mains, uses three Mullard valves: an EF86, an EL84 and an EZ80. The circuit given in Fig. 1 includes three controls: volume (RV1), treble (RV2) and bass (RV11). A modified version of this circuit, which allows the amplifier to be used with a pre-amplifier or in stereophonic equipment, is shown in Fig. 2. In this version, the three controls have been omitted, and the feedback network has been simplified.

The comparatively high sensitivity of the amplifier (100mV for 3W) permits the use of all types of crystal pick-up head and allows, if required, the use of equaliser networks between the head and amplifier. The output terminations of the circuit are suitable for almost all kinds of loudspeaker, but, although the circuit is designed to make the most effective use of the single output valve, the best possible results will

only be achieved if a suitably housed high-quality speaker is used.

CIRCUIT DESCRIPTION

Because of the inherently high level of distortion with single-ended output stages, appreciable negative feedback around the output stage is necessary to produce an output of acceptable quality. At the same time, an overall sensitivity of 100mV is required if the amplifier is to be suitable for use with any type of crystal pick-up head. (The attenuation resulting from pick-up equalisation with passive RC networks must also be borne in mind.)

The basic sensitivity of the circuit without feedback should be about 10mV in order that the desirable level of feedback (about 20dB) can be provided. From considerations of stability, this feedback should be taken around the minimum number of stages.



Prototype of Three-watt Amplifier

The EF86 in the voltage-amplifying stage is used under conditions approaching those of starvation operation. With a high value of anode load resistance (R5 is 1M Ω) and reduced values of anode and screen-grid voltage, the gain of the stage is raised two or three times above that obtained under normal operating conditions. This increase is attributable mainly to the fact that, because the voltage at the anode of the EF86 is very low, direct coupling can be used between this anode and the control grid of the EL84 in the output stage. Thus the shunt loading on the anode circuit of the EF86 is least at low and medium frequencies.

The use of direct coupling between the stages necessitates a higher cathode voltage in the output stage than is required with RC coupling. The value of R13 is thus greater than is usual for the cathode resistance. The screen-grid voltage for the EF86 is taken from the cathode of the EL84. In this way, negative d.c. feedback (which is essential in a directly coupled circuit to stabilise the operating conditions of both stages) is applied to the voltage amplifier.

Negative a.c. feedback is applied from the secondary winding of the output transformer to the cathode of the EF86. In Fig. 1, this feedback loop incorporates the bass-boost control, the amount of feedback being

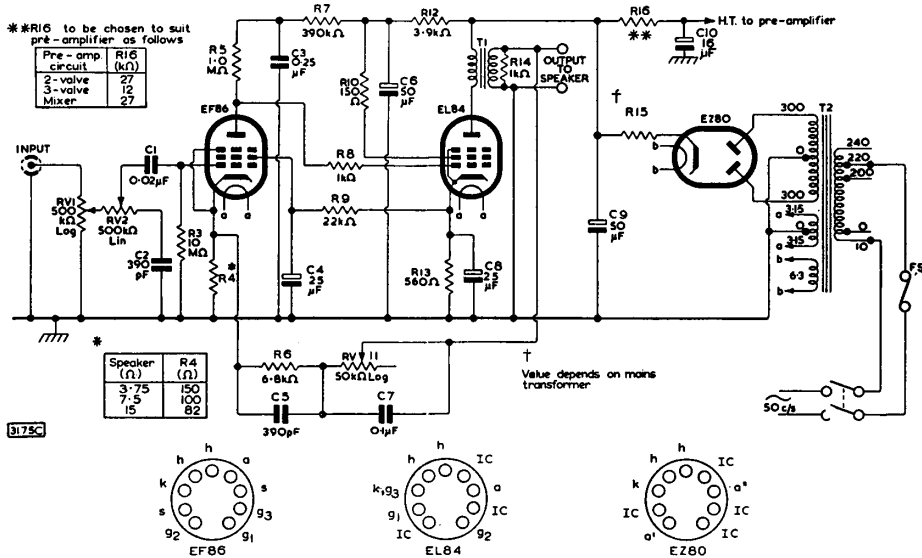

Fig. 1—Complete circuit diagram of amplifier

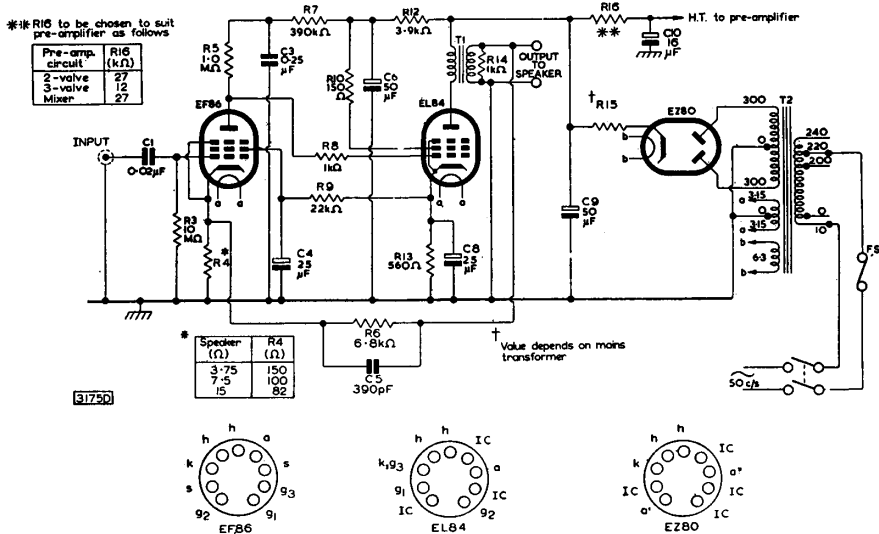

Fig. 2—Circuit diagram of control-less amplifier

changed continuously at low frequencies as the resistance of the control potentiometer RV11 is varied. In the simplified version of the circuit, the control RV11 is omitted, and the feedback loop consists of R6 and C5 only.

Provision for volume and treble control is made at the input of the amplifier. The potentiometers RV1 and RV2 constitute these controls respectively. In the control-less version of the amplifier, the output is taken directly to the capacitor C1 in the control-

grid circuit of the EF86.

The power supply uses the EZ80 in combination with a mains transformer meeting the specification given below. The resistor R15 between the cathode of the EZ80 and the reservoir capacitor C9 is for voltage control. The anode of the EL84 is supplied from C9, and the screen-grid is supplied through another filter network R12, C6. The h.t. supply for a pre-amplifier is taken from C9. Extra smoothing is provided by R16 and C10.

LIST OF COMPONENTS

Components indicated with an asterisk are not used in the control-less version of the amplifier.

Resistors

Circuit ref.	Value	Tolerance ($\pm\%$)	Rating (W)
*RV1	500 k Ω	logarithmic potentiometer	
*RV2	500 k Ω	linear potentiometer	
R3	10 M Ω	20	$\frac{1}{2}$
R4 for 15 Ω speaker	82 Ω	5	$\frac{1}{2}$
for 7.5 Ω speaker	100 Ω	5	$\frac{1}{2}$
for 3.75 Ω speaker	150 Ω	5	$\frac{1}{2}$
*R5	1 M Ω	10	$\frac{1}{2}$
R6	6.8k Ω	5	$\frac{1}{2}$
R7	390 k Ω	10	$\frac{1}{2}$
R8	1 k Ω	20	$\frac{1}{2}$
R9	22 k Ω	10	$\frac{1}{2}$
R10	150 Ω	20	$\frac{1}{2}$
*RV11	50 k Ω	logarithmic potentiometer	
R12	3.9k Ω	10	$\frac{1}{2}$
*R13	560 Ω	5	$\frac{1}{2}$
R14	1 k Ω	20	$\frac{1}{2}$
R15 value depends on mains transformer, 330 Ω in prototype		20	2
R16			
for 2-valve pre-amp.	27	10	$\frac{1}{2}$
for 3-valve pre-amp.	12	10	$\frac{1}{2}$
for input mixer	27	10 Ω	$\frac{1}{2}$

1. High stability, cracked carbon
2. Wire wound

Output Transformer T1

Primary Impedance, 5k Ω

Commercial Components

Manufacturer	Type/No.
Colne	03077
Elden	1264
Elstone	OT/3
Gardners	AS.7003
Gilson	W.O.767
Hinchley	1379
Parmeko	P2641
Partridge	P4073
Wynall	W1452

Valves

Mullard EF86, EL84, EZ80

Valveholders

B9A (noval) (two). McMurdo, BM9/U
 B9A (noval) (one), nylon-loaded with screening skirt.
 McMurdo, XM9/UC.1

Capacitors

Circuit ref.	Value	Description	Rating (V)
C1	0.02 μ F	paper	150
*C2	390 pF $\pm 20\%$	silvered mica	
C3	0.25 μ F	paper	350
C4	25 μ F	electrolytic	50
C5	390 pF $\pm 10\%$	silvered mica	
C6, C9	50 + 50 μ F	double electrolytic	350
*C7	0.1 μ F	paper	150
C8	25 μ F	electrolytic	50
C10	16 μ F	electrolytic	350

Mains Transformer

Primary: 10-0-200-220-240V.

Secondaries: H.T. 300-0-300V, 60mA.

L.T. 3.15-0-3.15V, 1A (for EF86, EL84).

0-6.3V, 1A (for EZ80).

If only one 6.3V secondary winding is available, it should have a 2A rating to supply all three valves.

Commercial Components

Manufacturer	Type No.
Colne	03097
Elden	890A
Elstone	MT3M
Gardners	RS.3103
Gilson	W.O.839
Hinchley	1442
Parmeko	P2631
Partridge	H300/60
Wynall	W1547

Miscellaneous

Mains input plug and socket, Bulgin, P.340
 Mains switch. N.S.F., 8370/B3
 Mains voltage selector. Chix, CTSP/2 + P.62/2
 H.T. supply plug and socket (pre-amplifier), 6-pin miniature.
 Bulgin P.194
 Fuse, Belling Lee Minifuse, L.575
 Lampholder (optional). Bulgin, D.180/red
 Indicator lamp (optional). 6.3V, 0.04A, M.E.S
 Input socket, coaxial. Belling Lee, L.604/S
 Output plug and socket. 2-pin. Bulgin, P.350
 Tagboard (10-way). Bulgin, C.125; Denco
 Pointer knob (three). Bulgin, K.370

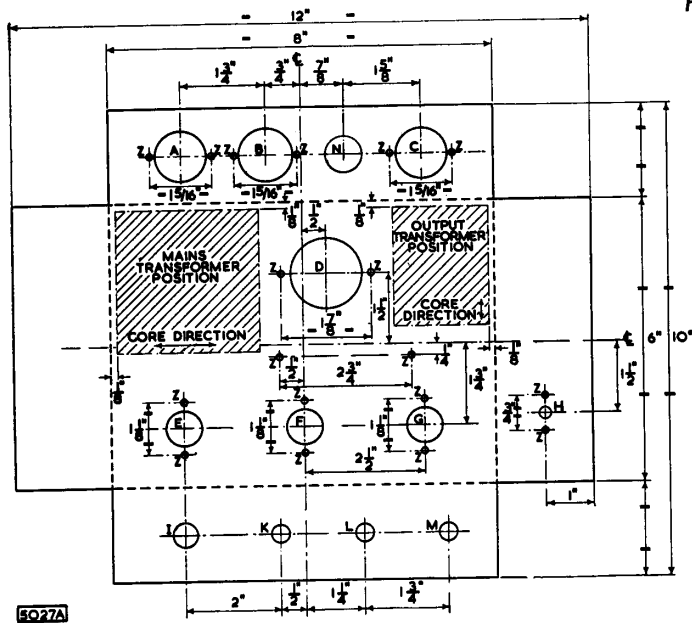

Fig. 3 (left)—Chassis details (The chassis should be bent up at 90° at all dotted lines)

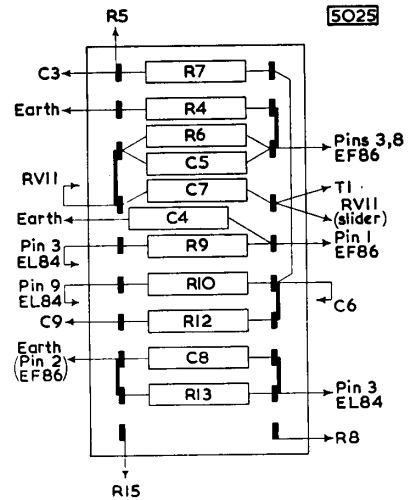

Fig. 4—Tagboard

KEY TO HOLES IN CHASSIS

Hole	Dimension	Use	Type No.
A	1/4 in. dia.	Mains input plug, 3-pin. Bulgin	P340
B	1 1/4 in. dia.	Voltage selector. Clix	CTSP/2
C	1 1/4 in. dia.	Output plug, 2-pin. Bulgin	P350
D	1 1/4 in. dia.	Electrolytic capacitor	—
E	1 in. dia.	B9A valveholder. McMurdo	BM9/U
F	1 in. dia.	B9A valveholder. McMurdo	BM9/U
G	1 in. dia.	B9A nylon-loaded valveholder with screening skirt. McMurdo	XM9/UC1
H	1/2 in. dia.	Input socket, coaxial. Belling Lee	L.604/S
I	1 in. dia.	Mains switch. N.S.F.	8370/B3
K	1 in. dia.	500kΩ logarithmic potentiometer	—
L	1 in. dia.	500kΩ linear potentiometer	—
M	1 in. dia.	500kΩ logarithmic potentiometer	—
N	1 in. dia.	H.T. supply plug, 6-pin miniature. Bulgin	P194
Z	Drill No. 34	6 B.A. clearance hole	—

CONSTRUCTION AND ASSEMBLY

Chassis details of the amplifier are given in Fig. 3. For the control-less version, holes for the potentiometers will not be required. The chassis can be cut from one piece of 16 s.w.g. aluminium sheet, 12 in. long and 10 in. wide. A bottom cover plate to the amplifier is not necessary.

A suitable arrangement of the components in the amplifier with controls is shown in Fig. 5. The position of the components on the tagboard is shown in Fig. 4. For the control-less version, the potentiometers RV1, RV2 and RV11 and the capacitors C2 and C7 are omitted. The capacitor C1 will be connected directly to the input socket, and the feedback path will be completed by connecting the appropriate junction of R6 and C5 to the speaker terminal.

If the can of the double electrolytic capacitor is used as the negative side, then it should be isolated from the chassis. The earth connection to the chassis should be made at the input socket only.

The mains transformer should have an h.t. rating of 300-0-300V, 60mA, and it is preferable, though not essential, that a separate l.t. winding (6.3V) be used for the EZ80 rectifier. This is indicated in the circuit diagram, and also in the list of components.

PERFORMANCE

Frequency Response

With the treble and bass controls in Fig. 1 in their minimum effective positions, or with the control-less circuit of Fig. 2, the frequency response is essentially flat from 35c/s to 30kc/s (Fig. 6). With maximum application of the respective controls, a treble cut of 20dB is available at 10kc/s, and a bass boost of 15dB is available at 70c/s. The bass boost is obtained by reducing the main feedback at low frequencies by means of RV11 and C7 (Fig.1).

Distortion

The relationship between the total harmonic distortion and the output power is shown in Fig. 7. It will be seen that, for a typical amplifier, for outputs above about 3.5W, the distortion increases rapidly. This indicates the point beyond which over loading of the amplifier occurs.

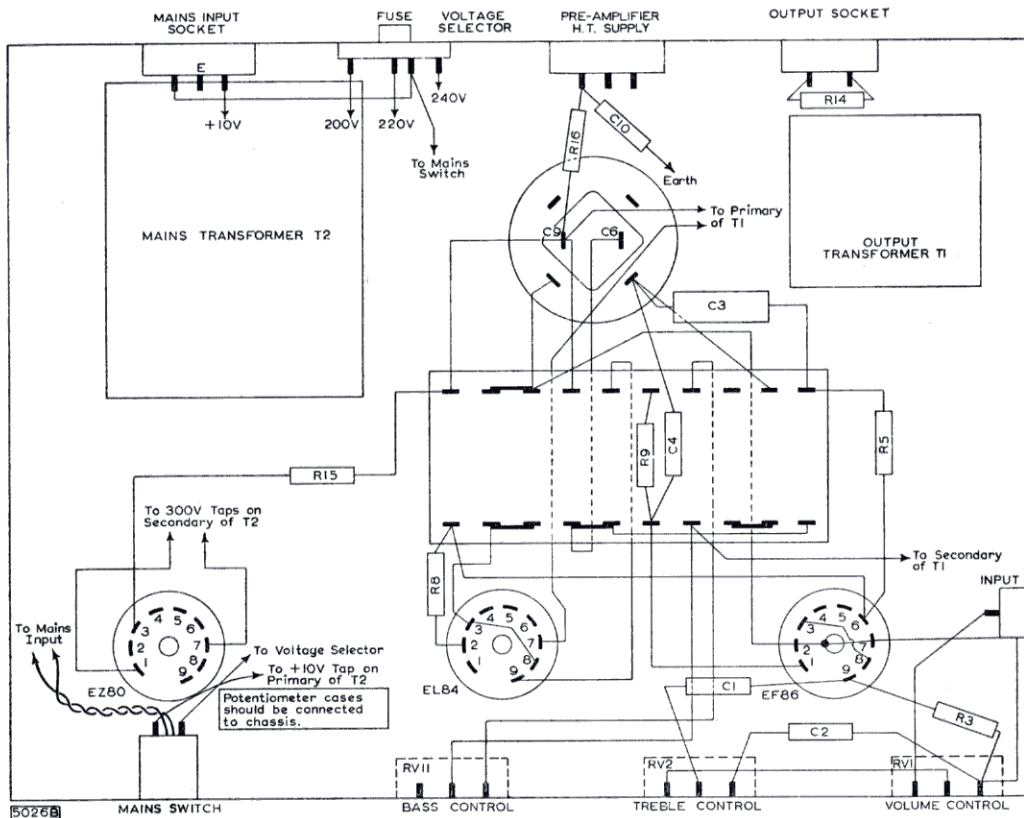
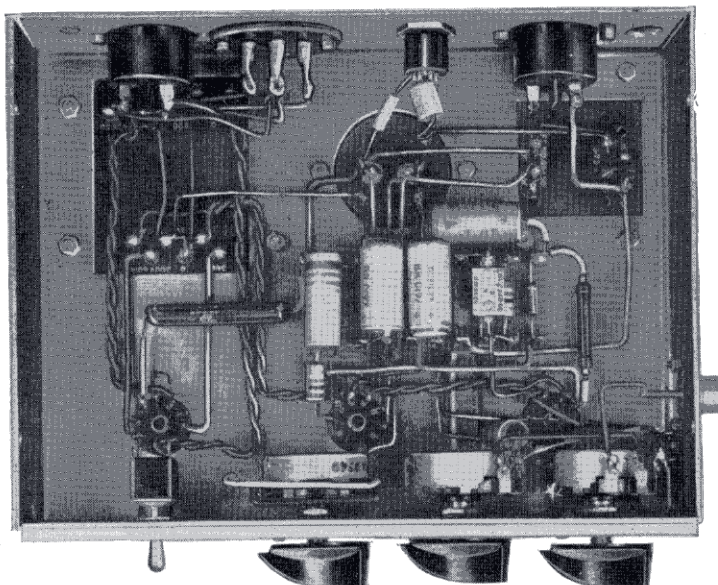

Fig. 5—Suggested layout of components



Underside of Prototype Amplifier

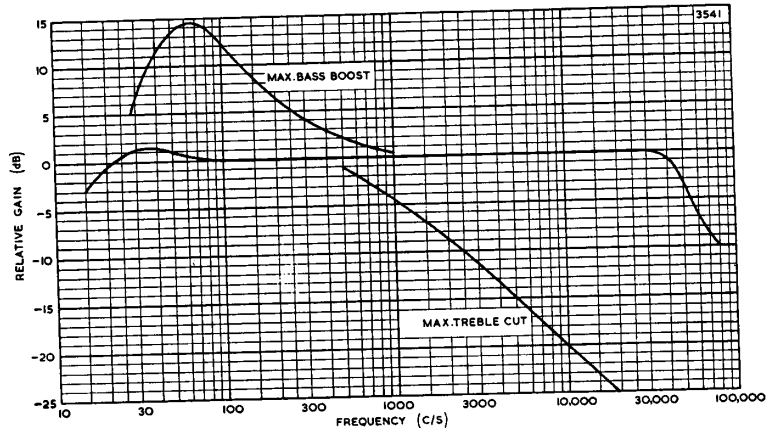

Fig. 6—Frequency response of amplifier showing relative gain without application of tone controls, and also showing relative gain with maximum application of tone controls

Output Impedance

The output impedance of the amplifier for a loud-speaker load of 15Ω is less than 1.5Ω . This gives an adequate damping factor of more than 10 (that is, $>15/1.5$).

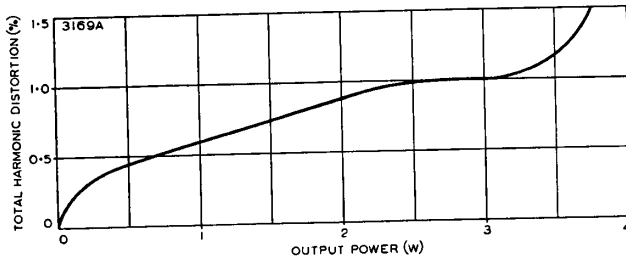

Fig. 7—Variation of total harmonic distortion with output power

D.C. CONDITIONS

The d.c. voltages at points in the equipment should be tested with reference to Table 1. The results shown in this table were obtained using an Avometer No. 8.

TABLE 1
D.C. Conditions

Point of Measurement	Voltages (V)	D.C. Range of Avometer* (V)
C9 C6 C3	310	1000
	290	1000
	210	1000
EL84 Anode Screen grid Cathode	290	1000
	290	1000
	28	100
EF86 Anode Screen grid	20	100
	28	100

*Resistance of Avometer
1000V-range, resistance = $20M\Omega$
100V-range, resistance = $2M\Omega$

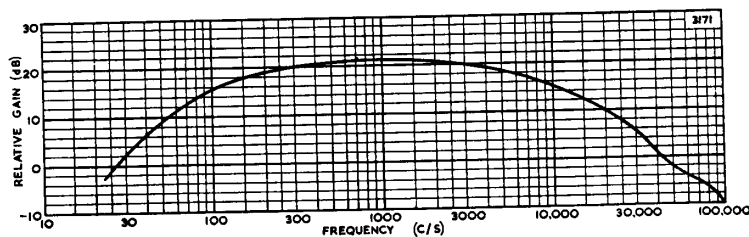

Fig. 8—Loop-gain characteristics