

6660

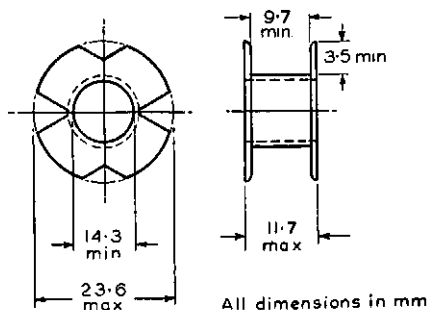

Single section coil former

DT2011—nylon, maximum working temperature = 130°C.

DT2084—polystyrene, maximum working temperature = 80°C.

The nylon is of a low water absorbent grade. Nominal winding area = 36.7mm<sup>2</sup>.

**WINDING DATA FOR FULLY WOUND FORMER  
ENAMELLED COPPER WIRE TO B.S.1844 (FINE COVERING)**

S.W.G.	Cu. dia. (in.)	Turns	Resistance (Ω)
20	0.036	28	0.042
21	0.032	44	0.088
22	0.028	50	0.125
23	0.024	72	0.25
24	0.022	80	0.33
25	0.020	105	0.53
26	0.018	136	0.86
27	0.0164	147	1.10
28	0.0148	188	1.75
29	0.0136	229	2.5
30	0.0124	260	3.5
31	0.0116	298	4.5
32	0.0108	340	6.0
33	0.0100	390	8.1
34	0.0092	465	11.5
35	0.0084	550	16
36	0.0076	665	24
37	0.0068	810	36
38	0.0060	1070	62
39	0.0052	1390	105
40	0.0048	1620	145
41	0.0044	1890	200
42	0.0040	2250	290
43	0.0036	2850	450
44	0.0032	3500	710
45	0.0028	4600	1200
46	0.0024	6100	2200
47	0.0020	8900	4600

## WINDING DATA FOR FULLY WOUND FORMER

### SILK COVERED BUNCHED ENAMELLED COPPER CONDUCTORS TO B.S.1258

Strands	S.W.G.	Strand dia. (in.)	Insulation	Turns	Resistance ( $\Omega$ )
81	43	0.0036	D.S.C.	22	0.043
350	48	0.0016	D.S.C.	22	0.050
315	48	0.0016	D.S.C.	24	0.061
81	44	0.0032	D.S.C.	25	0.061
280	48	0.0016	D.S.C.	25	0.071
252	48	0.0016	D.S.C.	27	0.085
81	45	0.0028	D.S.C.	27	0.087
224	48	0.0016	D.S.C.	27	0.096
200	48	0.0016	D.S.C.	30	0.120
180	48	0.0016	D.S.C.	42	0.185
48	44	0.0032	D.S.C.	42	0.175
160	48	0.0016	D.S.C.	44	0.22
140	48	0.0016	D.S.C.	46	0.26
30	43	0.0036	S.S.C.	62	0.32
81	47	0.0020	D.S.C.	65	0.41
30	44	0.0032	S.S.C.	70	0.46
100	48	0.0016	D.S.C.	72	0.57
30	45	0.0028	S.S.C.	96	0.83
81	48	0.0016	D.S.C.	96	0.94
30	46	0.0024	S.S.C.	129	1.50
19	45	0.0028	S.S.C.	136	1.85
30	47	0.0020	S.S.C.	176	3.0
7	42	0.0040	S.S.C.	216	3.9
10	45	0.0028	S.S.C.	255	6
9	45	0.0028	S.S.C.	280	8
7	45	0.0028	S.S.C.	400	15
3	44	0.0032	S.S.C.	550	36
3	46	0.0024	S.S.C.	820	96

# VINKOR ADJUSTABLE POT CORE

# LA2203

30mm adjustable pot core specially designed for high quality inductors operating at frequencies up to approximately 30kc/s.

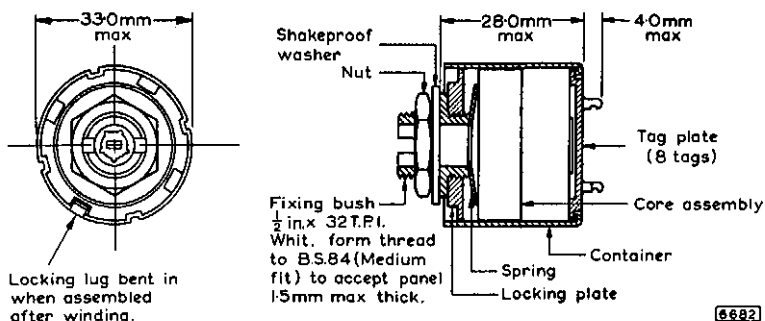

Dimensions of hexagonal nut are 0.69in. max. across the flats by 0.1in. max. thickness.

## ELECTRICAL AND MAGNETIC PROPERTIES OF CORE ASSEMBLY

with adjuster at nominal mid-range position.

Effective permeability	$\mu_e$	*160
Turns for 1mH	$\alpha$	37.5
Initial permeability of material	$\mu_i$	
Minimum		1000
Typical		1200
Residual plus eddy current dissipation factor measured at:	$\tan \delta_{r+e}$	
B max. < 0.5 gauss, f = 30kc/s		
Typical		$0.80 \times 10^{-3}$
Maximum		$1.44 \times 10^{-3}$
B max. < 0.5 gauss, f = 100kc/s		
Typical		$1.76 \times 10^{-3}$
Maximum		$2.40 \times 10^{-3}$
Hysteresis factor measured at 4 kc/s	$F_h = \frac{R}{L} \cdot \frac{1}{l_f \sqrt{L}}$	
Typical		9.8
Maximum		14.75
Temperature coefficient over the range 20 to 50°C	$\frac{\Delta L}{L \cdot \Delta T}$	0 to +320 p.p.m./°C

\*Without the adjuster, the effective permeability of the core is  $148.3 \pm 3\%$ .

## GENERAL NOTES

Coil formers are not supplied with the Vinkor but should be ordered separately. For details see page 3.

For correct assembly and adjustment of piece parts use aligning plug type DT2035. See separate data sheet.

Non-magnetic screwdriver type DT2047 should be used for precise adjustment of inductance.

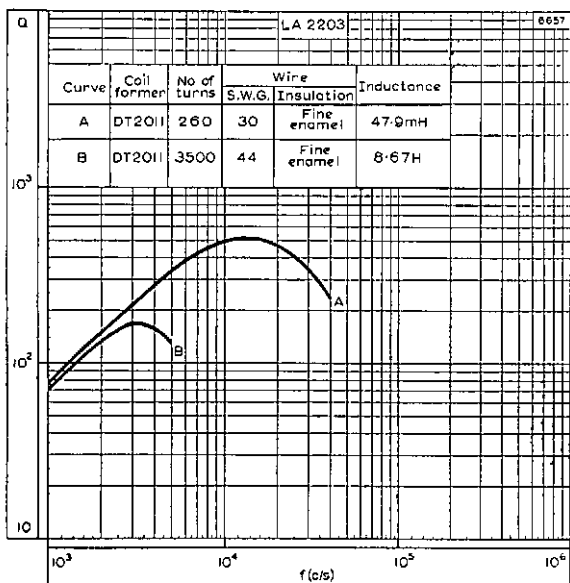

TYPICAL Q CURVES

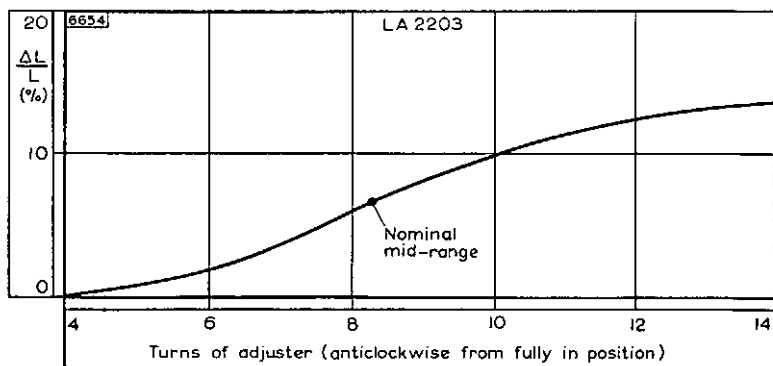

ADJUSTMENT CURVE

# VINKOR ADJUSTABLE POT CORE

# LA2204

30mm adjustable pot core specially designed for high quality inductors operating at frequencies up to approximately 70kc/s.

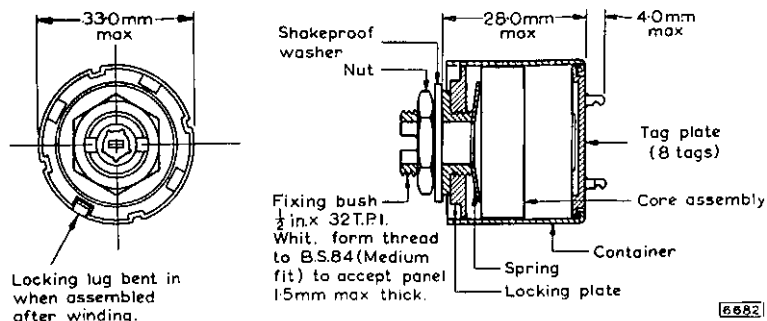

Dimensions of hexagonal nut are 0.69in. max. across the flats by 0.1in. max. thickness.

## ELECTRICAL AND MAGNETIC PROPERTIES OF CORE ASSEMBLY with adjuster at nominal mid-range position.

Effective permeability	$\mu_e$	*100
Turns for 1mH	$\alpha$	47.5
Initial permeability of material	$\mu_i$	
Minimum		1000
Typical		1200
Residual plus eddy current dissipation factor measured at:	$\tan \delta_{r+c}$	
B max. < 0.5 gauss, f = 30kc/s		
Typical		$0.50 \times 10^{-3}$
Maximum		$0.90 \times 10^{-3}$
B max. < 0.5 gauss, f = 100kc/s		
Typical		$1.10 \times 10^{-3}$
Maximum		$1.50 \times 10^{-3}$
Hysteresis factor measured at 4kc/s	$F_h = \frac{R}{L} \cdot \frac{1}{1.4\sqrt{L}}$	
Typical		4.9
Maximum		7.3
Temperature coefficient over the range 20 to 50°C	$\frac{\Delta L}{L \cdot \Delta T}$	0 to +200 p.p.m./°C

\*Without the adjuster, the effective permeability of the core is  $90.0 \pm 3\%$ .

## GENERAL NOTES

Coil formers are not supplied with the Vinkor but should be ordered separately. For details see page 3.

For correct assembly and adjustment of piece parts use aligning plug type DT2035. See separate data sheet.

Non-magnetic screwdriver type DT2047 should be used for precise adjustment of inductance.



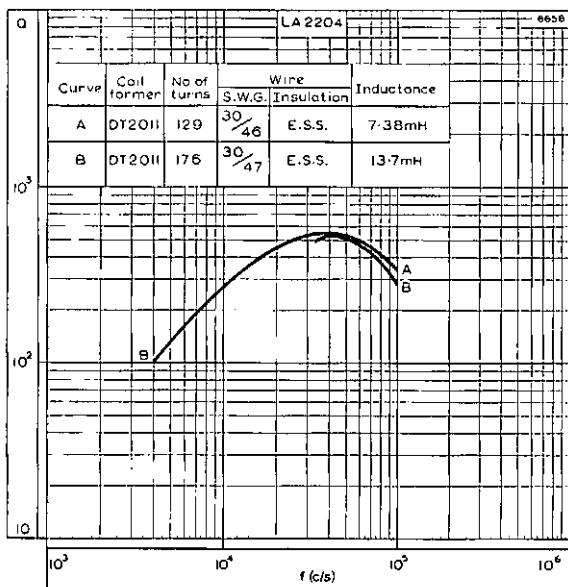

**TYPICAL Q CURVES**

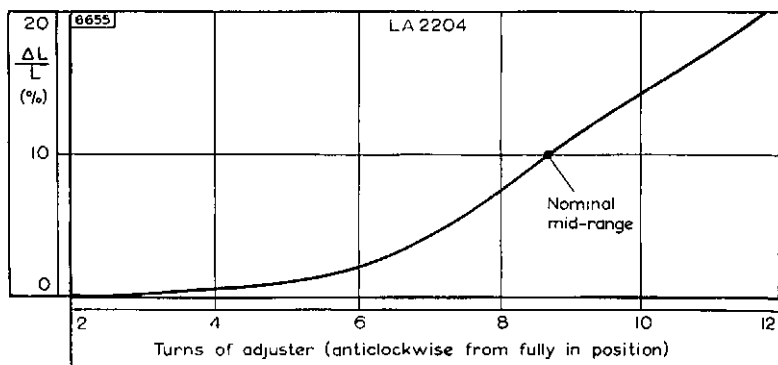

**ADJUSTMENT CURVE**

6660

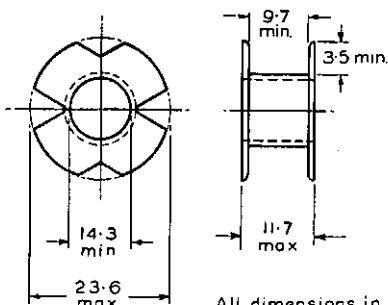

All dimensions in mm

Single section coil former

DT2011—nylon, maximum working temperature = 130°C.

DT2084—polystyrene, maximum working temperature = 80°C.

The nylon is of a low water absorbent grade. Nominal winding area = 36.7mm<sup>2</sup>.

**WINDING DATA FOR FULLY WOUND FORMER  
ENAMELLED COPPER WIRE TO B.S.1844 (FINE COVERING)**

S.W.G.	Cu. dia. (in.)	Turns	Resistance (Ω)
20	0.036	28	0.042
21	0.032	44	0.088
22	0.028	50	0.125
23	0.024	72	0.25
24	0.022	80	0.33
25	0.020	105	0.53
26	0.018	136	0.86
27	0.0164	147	1.10
28	0.0148	188	1.75
29	0.0136	229	2.5
30	0.0124	260	3.5
31	0.0116	298	4.5
32	0.0108	340	6.0
33	0.0100	390	8.1
34	0.0092	465	11.5
35	0.0084	550	16
36	0.0076	665	24
37	0.0068	810	36
38	0.0060	1070	62
39	0.0052	1390	105
40	0.0048	1620	145
41	0.0044	1890	200
42	0.0040	2250	290
43	0.0036	2850	450
44	0.0032	3500	710
45	0.0028	4600	1200
46	0.0024	6100	2200
47	0.0020	8900	4600



## WINDING DATA FOR FULLY WOUND FORMER

SILK COVERED BUNCHED ENAMELLED COPPER CONDUCTORS  
TO B.S.1258

Strands	S.W.G.	Strand dia. (in.)	Insulation	Turns	Resistance ( $\Omega$ )
81	43	0.0036	D.S.C.	22	0.043
350	48	0.0016	D.S.C.	22	0.050
315	48	0.0016	D.S.C.	24	0.061
81	44	0.0032	D.S.C.	25	0.061
280	48	0.0016	D.S.C.	25	0.071
252	48	0.0016	D.S.C.	27	0.085
81	45	0.0028	D.S.C.	27	0.087
224	48	0.0016	D.S.C.	27	0.096
200	48	0.0016	D.S.C.	30	0.120
180	48	0.0016	D.S.C.	42	0.185
48	44	0.0032	D.S.C.	42	0.175
160	48	0.0016	D.S.C.	44	0.22
140	48	0.0016	D.S.C.	46	0.26
30	43	0.0036	S.S.C.	62	0.32
81	47	0.0020	D.S.C.	65	0.41
30	44	0.0032	S.S.C.	70	0.46
100	48	0.0016	D.S.C.	72	0.57
30	45	0.0028	S.S.C.	96	0.83
81	48	0.0016	D.S.C.	96	0.94
30	46	0.0024	S.S.C.	129	1.50
19	45	0.0028	S.S.C.	136	1.85
30	47	0.0020	S.S.C.	176	3.0
7	42	0.0040	S.S.C.	216	3.9
10	45	0.0028	S.S.C.	255	6.0
9	45	0.0028	S.S.C.	280	8.0
7	45	0.0028	S.S.C.	400	15
3	44	0.0032	S.S.C.	550	36
3	46	0.0024	S.S.C.	820	96



# VINKOR ADJUSTABLE POT CORE

# LA2205

30mm adjustable pot core specially designed for high quality inductors operating at frequencies up to approximately 200kc/s.

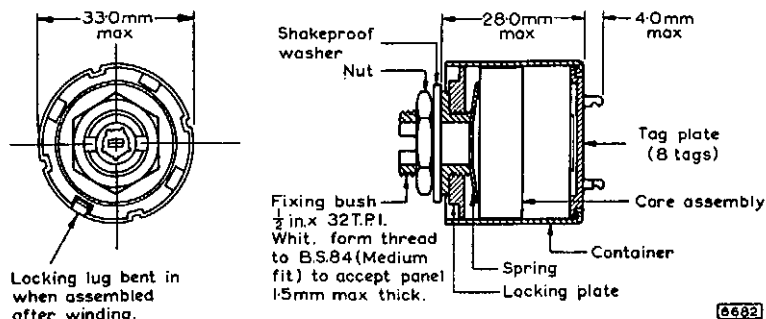

Dimensions of hexagonal nut are 0.69in. max. across the flats by 0.1in. max. thickness.

## ELECTRICAL AND MAGNETIC PROPERTIES OF CORE ASSEMBLY

with adjuster at nominal mid-range position.

Effective permeability	$\mu_e$	*63
Turns for 1mH	$\alpha$	59.8
Initial permeability of material	$\mu_i$	
Minimum		1000
Typical		1200
Residual plus eddy current dissipation factor measured at:	$\tan \delta_{r+e}$	
B max. < 0.5 gauss, f = 30kc/s		
Typical		$0.3 \times 10^{-3}$
Maximum		$0.57 \times 10^{-3}$
B max. < 0.5 gauss, f = 100kc/s		
Typical		$0.7 \times 10^{-3}$
Maximum		$0.95 \times 10^{-3}$
Hysteresis factor measured at 4kc/s	$F_h = \frac{R_h}{L} \cdot \frac{1}{f\sqrt{L}}$	
Typical		2.4
Maximum		3.65
Temperature coefficient over the range 20 to 50°C	$\frac{\Delta L}{L \cdot \Delta T}$	0 to +126 p.p.m./°C

\*Without the adjuster, the effective permeability of the core is  $59.5 \pm 2\%$ .

## GENERAL NOTES

Coil formers are not supplied with the Vinkor but should be ordered separately. For details see page 3.

For correct assembly and adjustment of piece parts use aligning plug type DT2035. See separate data sheet.

Non-magnetic screwdriver type DT2047 should be used for precise adjustment of inductance.

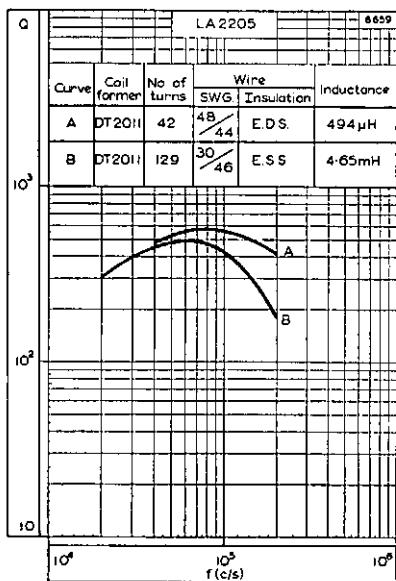

**TYPICAL Q CURVES**

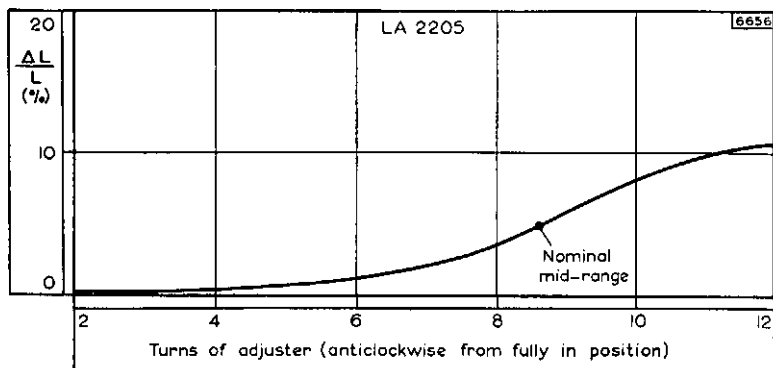

**ADJUSTMENT CURVE**

6860

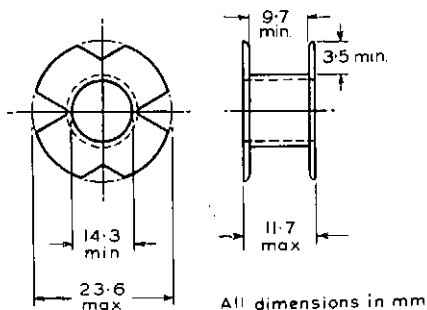

Single section coil former

DT2011—nylon, maximum working temperature = 130°C.

DT2084—polystyrene, maximum working temperature = 80°C.

The nylon is of a low water absorbent grade. Nominal winding area = 36.7mm<sup>2</sup>

**WINDING DATA FOR FULLY WOUND FORMER  
ENAMELLED COPPER WIRE TO B.S.1844 (FINE COVERING)**

S.W.G.	Cu. dia. (in.)	Turns	Resistance (Ω)
20	0.036	28	0.042
21	0.032	44	0.088
22	0.028	50	0.125
23	0.024	72	0.25
24	0.022	80	0.33
25	0.020	105	0.53
26	0.018	136	0.86
27	0.0164	147	1.10
28	0.0148	188	1.75
29	0.0136	229	2.5
30	0.0124	260	3.5
31	0.0116	298	4.5
32	0.0108	340	6.0
33	0.0100	390	8.1
34	0.0092	465	11.5
35	0.0084	550	16
36	0.0076	665	24
37	0.0068	810	36
38	0.0060	1070	62
39	0.0052	1390	105
40	0.0048	1620	145
41	0.0044	1890	200
42	0.0040	2250	290
43	0.0036	2850	450
44	0.0032	3500	710
45	0.0028	4600	1200
46	0.0024	6100	2200
47	0.0020	8900	4600



## WINDING DATA FOR FULLY WOUND FORMER

### SILK COVERED BUNCHED ENAMELLED COPPER CONDUCTORS TO B.S.1258

Strands	S.W.G.	Strand dia. (in.)	Insulation	Turns	Resistance ( $\Omega$ )
81	43	0.0036	D.S.C.	22	0.043
350	48	0.0016	D.S.C.	22	0.050
315	48	0.0016	D.S.C.	24	0.061
81	44	0.0032	D.S.C.	25	0.061
280	48	0.0016	D.S.C.	25	0.071
252	48	0.0016	D.S.C.	27	0.085
81	45	0.0028	D.S.C.	27	0.087
224	48	0.0016	D.S.C.	27	0.096
200	48	0.0016	D.S.C.	30	0.120
180	48	0.0016	D.S.C.	42	0.185
48	44	0.0032	D.S.C.	42	0.175
160	48	0.0016	D.S.C.	44	0.22
140	48	0.0016	D.S.C.	46	0.26
30	43	0.0036	S.S.C.	62	0.32
81	47	0.0020	D.S.C.	65	0.41
30	44	0.0032	S.S.C.	70	0.46
100	48	0.0016	D.S.C.	72	0.57
30	45	0.0028	S.S.C.	96	0.83
81	48	0.0016	D.S.C.	96	0.94
30	46	0.0024	S.S.C.	129	1.50
19	45	0.0028	S.S.C.	136	1.85
30	47	0.0020	S.S.C.	176	3.0
7	42	0.0040	S.S.C.	216	3.9
10	45	0.0028	S.S.C.	255	6.0
9	45	0.0028	S.S.C.	280	8.0
7	45	0.0028	S.S.C.	400	15
3	44	0.0032	S.S.C.	550	36
3	46	0.0024	S.S.C.	820	96